

**olivetti**

PROGRAMMA 101

GENERAL REFERENCE MANUAL

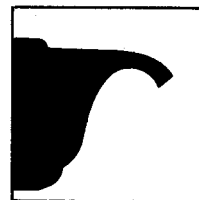

Programma 101  
general  
reference  
manual

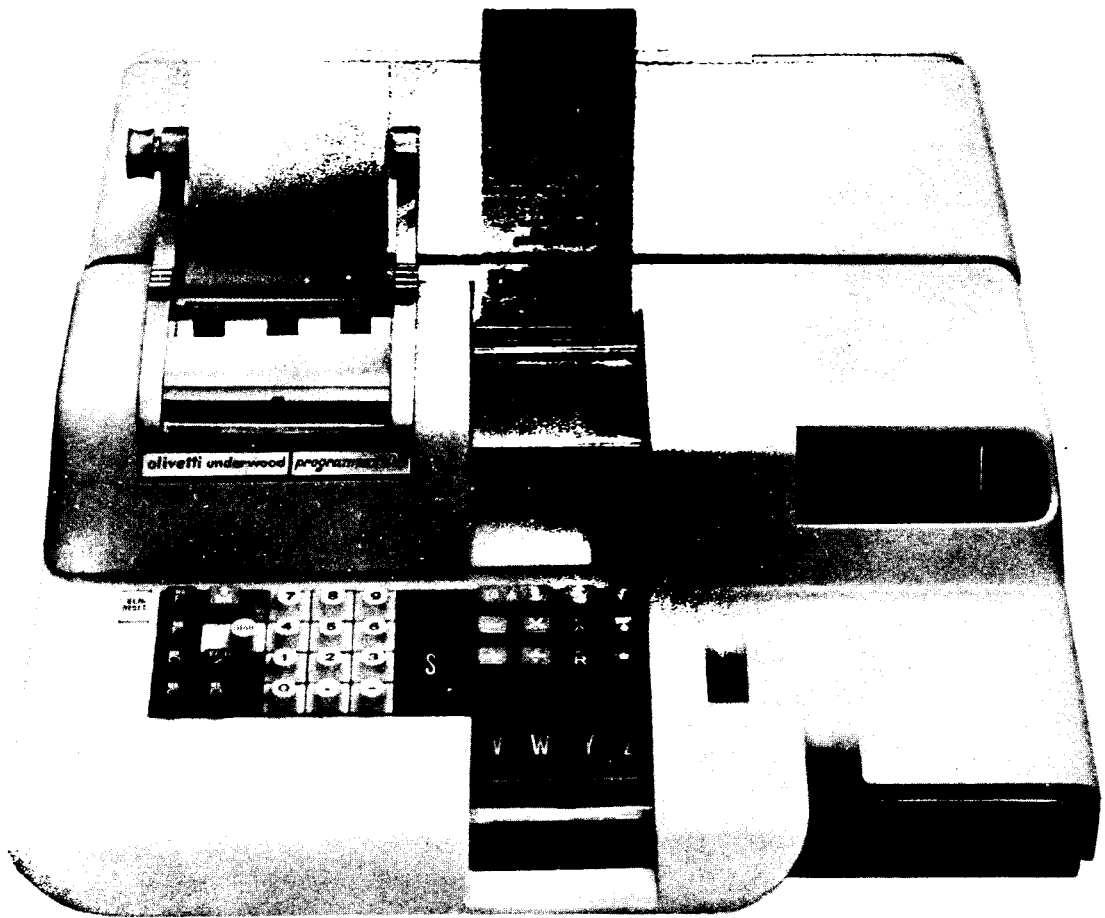

*Programma 101 is a completely self-contained desk-top machine capable of operating in manual mode as a high speed electronic printing calculator, in program mode as an automatic computer with the ability to follow stored instructions, or in a combination of the two modes.*

*This manual discusses the operation and capabilities of Programma 101 in all of its modes. It is divided into a description of the computer, an explanation of its program language, and a brief presentation of the procedures and techniques for its programming and use.*

	Page
<b>Computer Components</b> .....	6
Memory .....	7
Keyboard .....	11
<b>Decimal Wheel</b> .....	15
<b>Split Register</b> .....	16
<b>General Operations</b> .....	17
Start-S .....	17
Clear .....	17
Print .....	17
Vertical Spacing .....	17
<b>Data Transfer Operations</b> .....	18
To A .....	18
From M .....	19
Exchange .....	20
D-R Exchange .....	21
Decimal Part To M .....	22
<b>Arithmetic Operations</b> .....	23
Addition .....	24
Subtraction .....	25
Multiplication .....	26
Division .....	27
Square Root .....	28
Absolute Value .....	29
<b>Jump Operations</b> .....	30
Unconditional Jumps .....	31
Conditional Jumps .....	32
<b>Constants</b> .....	34
Constants in Registers .....	34
Constants as Instructions .....	35
<b>Computer Utilization</b> .....	36
To Record a Program .....	36
Read/Record D and E .....	37
To Print a Program .....	37
To Use a Program .....	38
Automatic Internal Checks .....	38
<b>Manual Mode</b> .....	39
<b>Computer Exercise</b> .....	40
<b>Changing The Ribbon</b> .....	42
<b>Insertion of Paper Roll</b> .....	43
<b>Programming Techniques</b> .....	44
Rounding Techniques .....	45
Instruction—Data Storage .....	47
Counters .....	50
Packing a Register .....	51
The Domino Technique .....	52
Chaining .....	53
Sample Program .....	54-60

# Computer Components

## Programma 101 is composed of the following elements:

*Memory:* To store numeric data and program instructions.

*Electric Keyboard:* For numeric entry, manual operation, and compiling program instructions.

*Printing Unit:* Serial printing, from right to left, at 30 characters per second; this unit prints all keyboard entries, programmed output and instructions.

*Magnetic Card Reader/Recorder:* The device through which instructions and constants for a program can be stored on, and retrieved from, a magnetic card.

*Control and Arithmetic Units:* The *Control Unit* is the administrative section of the computer. It receives the incoming information, determines the computation to be performed and directs the *Arithmetic Unit* where to find the information and what operation to perform.

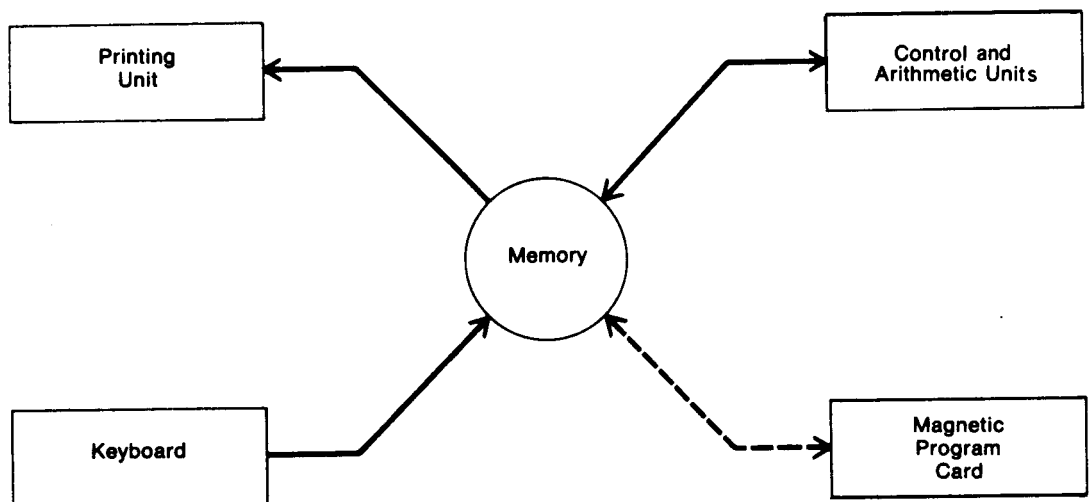

## Memory

The memory is composed of ten registers. Eight are storage registers and two are used exclusively for instructions.

The two instruction registers can store a total of 48 instructions.

The eight storage registers, M, A, R, B, C, D, E and F, have a capacity of 22 digits, plus decimal point and sign.

Three of these registers, M, A and R, are operating registers and take part in all arithmetic operations.

*The M register is the Median or distributive register. ALL keyboard figure entries are held in the M register and distributed to the other registers as instructed.*

*The A register functions with the arithmetic unit to form the Accumulator. Arithmetic results are developed and retained in the A register. A result of up to 23 digits can be produced in the A register.*

**The R register retains:**

- The complete results in addition and subtraction.
- The complete product in multiplication.
- The remainder in division.
- A nonfunctional remainder in square root.

The five remaining registers, B, C, D, E, and F, are storage registers. Each can be split into two registers with a capacity of 11 digits, plus decimal point and sign.

When storage registers are split, the right portion of the split register retains its original designation, while the left side is identified with the corresponding lower case letter. The lower case designation is obtained by entering the corresponding upper case letter and depressing the "/" key, e.g. c = C/.

The registers F, E and D and their splits have the additional capability of storing program instructions and constants to be used within programs.

When these registers or their splits are used as instruction registers, the instructions follow an overflow pattern, so that after the instruction registers are at capacity, the remaining instructions will be received first by F, then f, then E, then e, then D, and finally d. Programs of up to 120 instructions can be stored internally, as shown above. When registers D, E and F and their splits are not used for instructions, they are free to store constants or intermediate results.

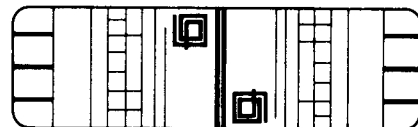
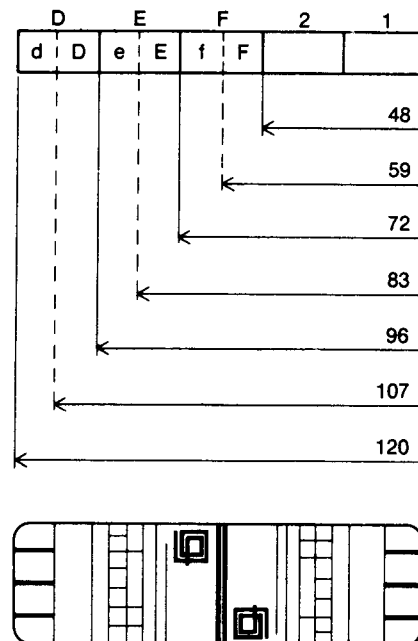

The following formats show the separation and capacities of the ten registers.

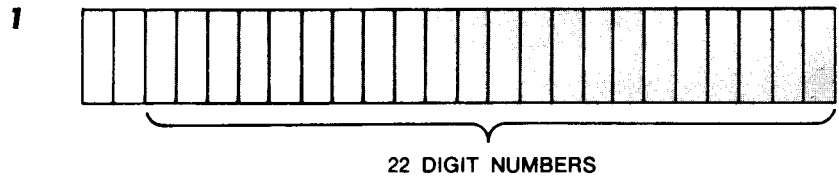

**Format 1** – This represents the storage registers used as complete registers: M, A, R: always complete; B, C, D, E, F: complete in this case.

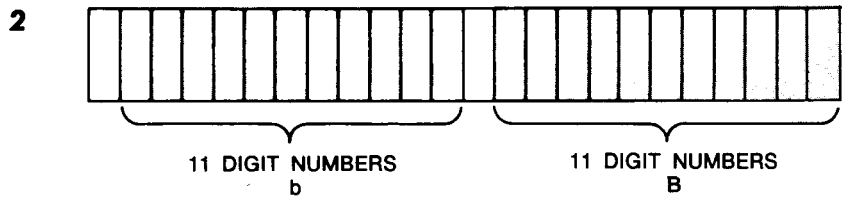

**Format 2** – This represents the storage registers when split: b, B; c, C; d, D; e, E; and f, F.

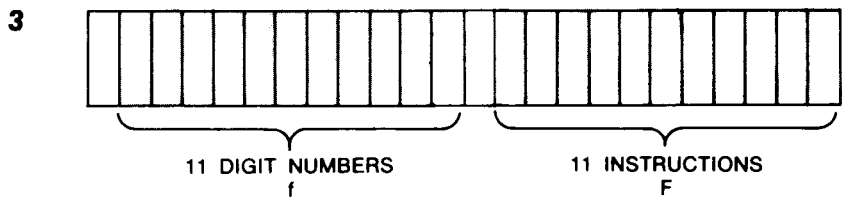

**Format 3** – This represents the split registers with numeric and instruction storage: e.g. d, D; e, E; and f, F.

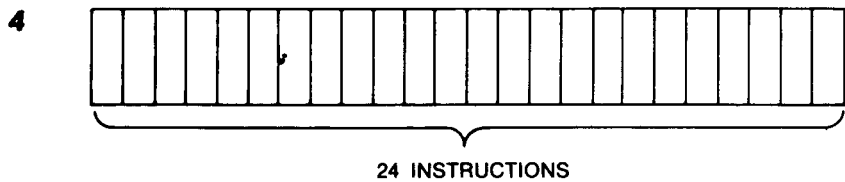

**Format 4** – This represents the complete instruction registers. Registers 1 and 2; registers F, E and D when used only for instructions.



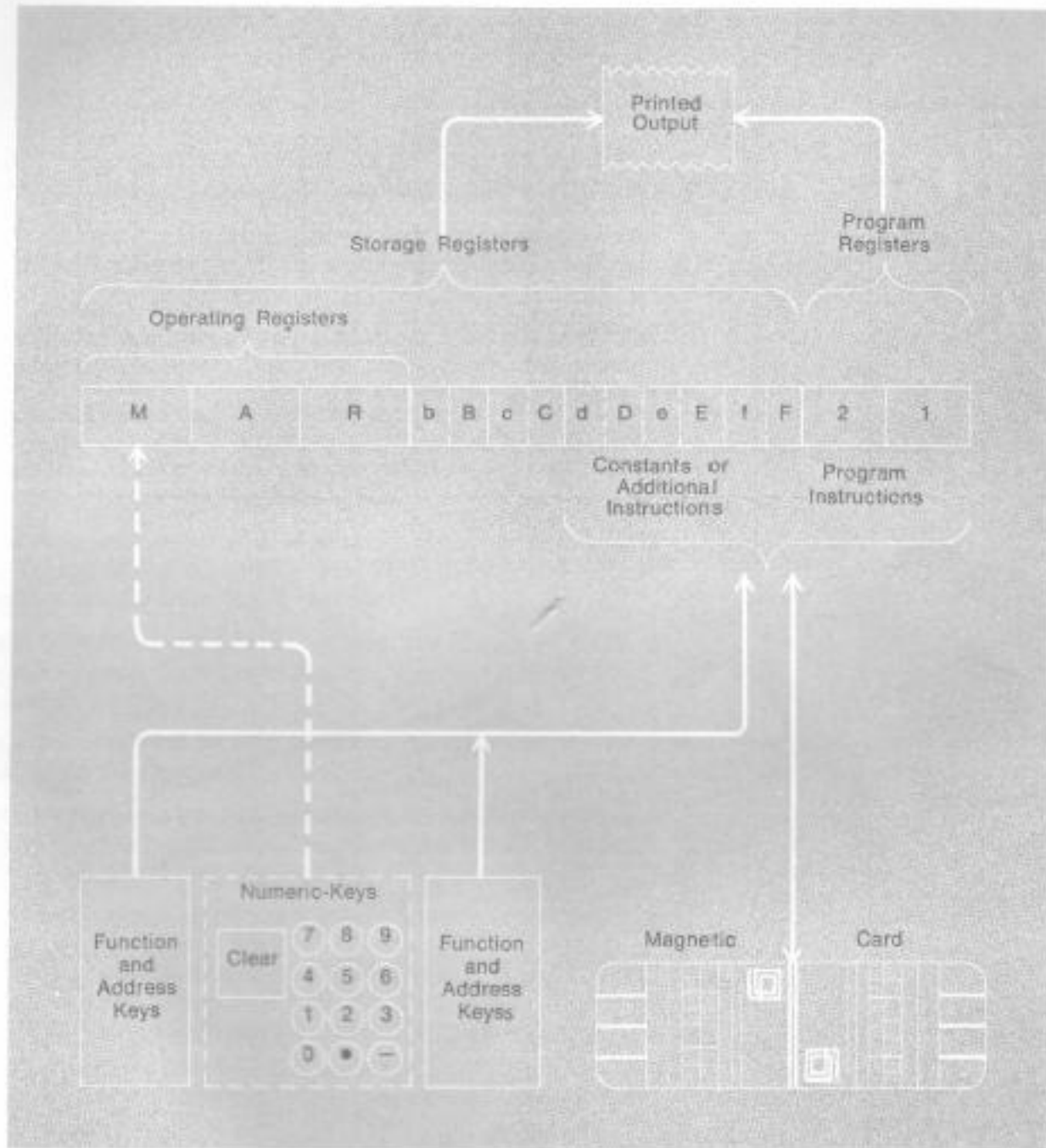

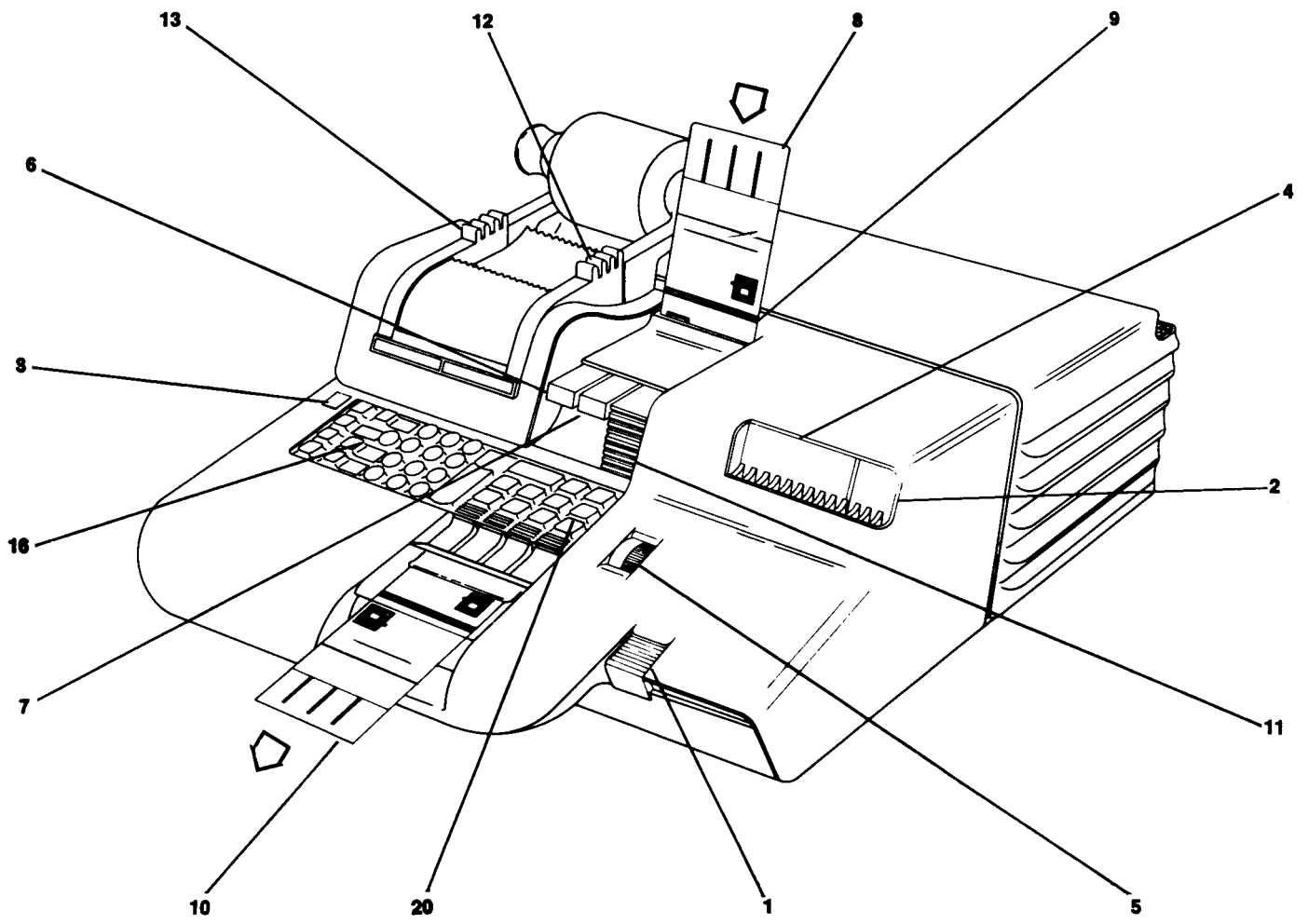

## Keyboard

- 1 The **ON-OFF KEY** is a dual purpose switch for both the ON and OFF positions. (Note: the OFF position automatically clears all stored data and instructions.)
- 2 The **ERROR (red) LIGHT** lights when the computer is turned on, and whenever the computer detects an operational error; e.g. exceeding capacity, division by zero.
- 3 The **GENERAL RESET KEY** erases all data and instructions from the computer and turns off the error light.
- 4 The **CORRECT PERFORMANCE (green) LIGHT** indicates the computer is functioning properly. A steady light indicates that the computer is ready for an operator decision; a flickering light indicates the computer is executing programmed instructions and that the keyboard is locked.
- 5 The **DECIMAL WHEEL** determines the number of decimal places to which computations will be carried out in the A register and the decimal places in the printed output, except for results from the R register.
- 6 The **RECORD PROGRAM SWITCH**, when ON (in), directs the computer to store instructions either in the memory from the keyboard, or onto a magnetic program card from the memory.  
The **RECORD PROGRAM SWITCH** must be OFF (out) to load instructions from a magnetic program card into the memory.
- 7 The **PRINT PROGRAM SWITCH**, when ON (in), directs the computer to print out the instructions stored in memory from its present location in the program to the next Stop instruction (S), whenever the Print key (20) is depressed.
- 8 The **MAGNETIC PROGRAM CARD** is a plastic card with a ferrous oxide backing, used to record programs magnetically for external storage. The card is inserted into a read/write device (9) to record instructions and/or constants into or from the computer memory. Once inserted, the card may be removed from the computer (10) without disturbing the stored instructions.  
(Note: the read/write device uses only half the magnetic card; consequently, two sets of 120 instructions and/or constants may be stored on a single card.)
- 11 The **KEYBOARD RELEASE KEY** reactivates a locked keyboard. If two or more keys are depressed simultaneously, the keyboard will lock to indicate a misoperation. Because the operator does not know what entry was accepted by the computer, after touching the Keyboard Release key the Clear Entry key (16) MUST next be depressed and the complete figure re-entered.
- 12 **TAPE ADVANCE** advances the paper tape.
- 13 **TAPE RELEASE LEVER** enables precise finger-tip adjustment when changing tape rolls.

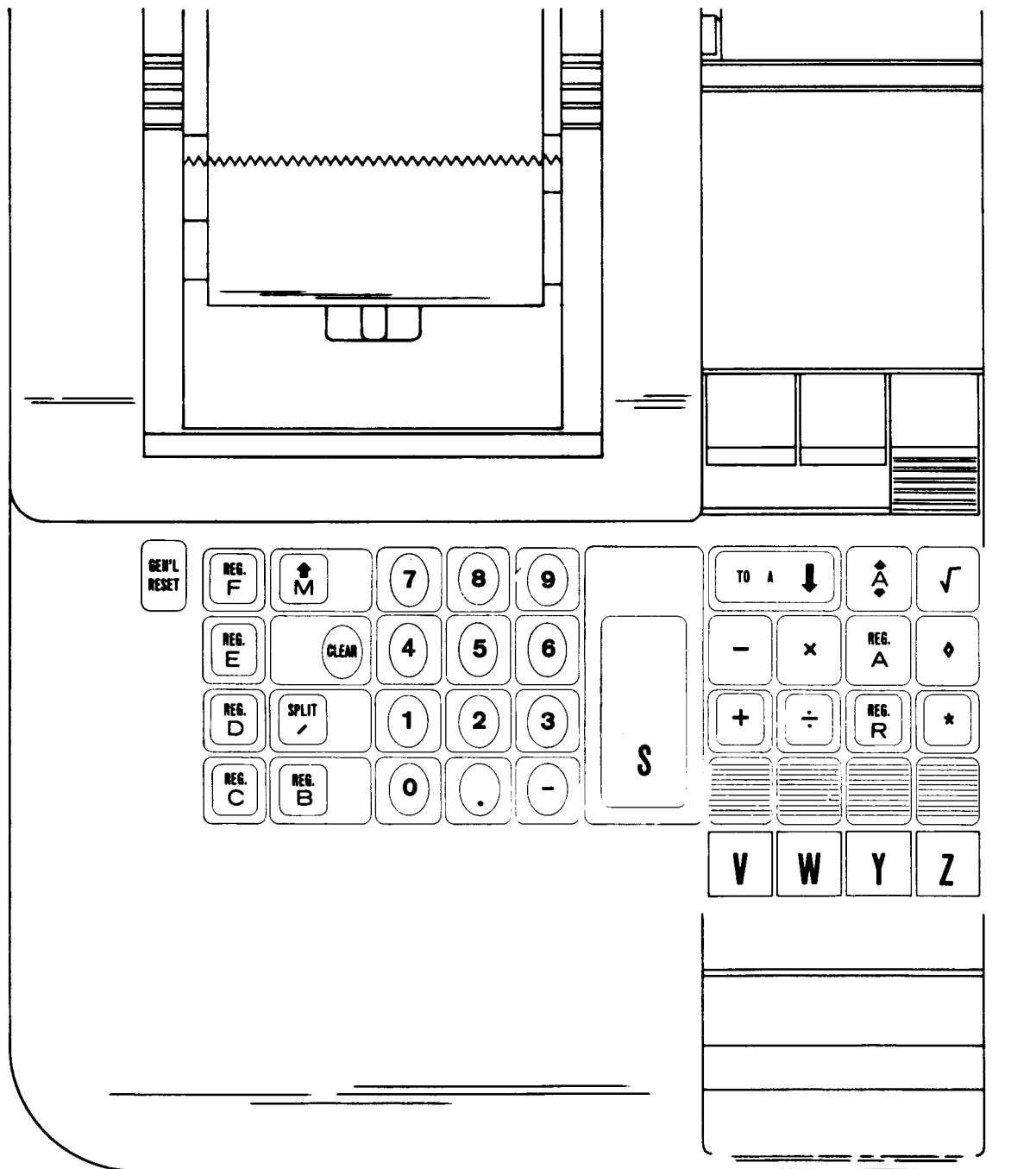

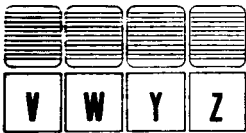

14 The **ROUTINE SELECTION KEYS V, W, Y and Z** direct the computer to the proper program or subroutine.

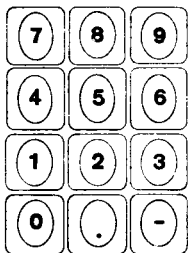

15 The **NUMERIC KEYBOARD** uses the ten-key entry system with provision for entry of a decimal point and a negative sign. Keyboard entries are automatically stored in the M register.



16 The **CLEAR ENTRY KEY** clears the entire keyboard entry. When keying in a program, a depression of the clear key will erase the last instruction that has been entered.

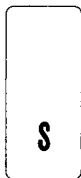

17 The **START KEY** restarts the computer in programmed operation and is used to code a stop instruction when keying in programs.

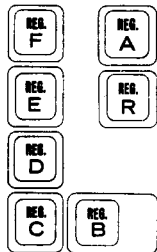

18 The **REGISTER ADDRESS KEYS A, B, C, D, E, F and R** identify the corresponding registers. The operating register M has no keyboard identification since the computer automatically relates all instructions to the M register unless instructed otherwise.



19 The **SPLIT KEY** combined with a register (e.g. C/) divides that register into two equal parts. When storage registers are split, the right portion of the split register retains the original designation while the left side is identified on the tape with the corresponding lower case letter (e.g. C/ = c).



20 The **PRINT KEY** prints the contents of an addressed register.



21 The **CLEAR KEY** clears the contents of an addressed register. When the computer is operated manually, a depression of this key will print the number in that register and clear it.

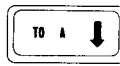

22 The **TRANSFER KEYS** perform transfer operations between the storage registers and the operating registers. (Refer to discussion of transfer operations for the function of each transfer key.)

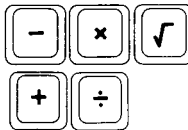

23 The **ARITHMETIC KEYS** perform their indicated arithmetic function.

## As it affects COMPUTATION:

The Decimal Wheel determines the number of decimal places to which the result of a calculation in the A register will be carried out. The Decimal Wheel has the following effect on these operations.

**ADDITION, SUBTRACTION, MULTIPLICATION:** *After the computation, the result in the A register is truncated according to the number of decimal places indicated by the setting of the Decimal Wheel. The complete result is retained in the R register.*

**DIVISION:** *The quotient is retained in the A register and is carried out only to the number of decimal places indicated by the setting of the Decimal Wheel.*

*The decimally correct remainder is retained in the R register.*

**SQUARE ROOT:** *The root is retained in the A register and is extracted to the number of decimal places indicated by the setting of the Decimal Wheel. The R register contains a non-functional remainder.*

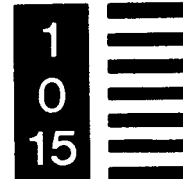

## As it affects KEYBOARD ENTRIES:

When entering decimal numbers, the Decimal Point key is touched in its proper position; e.g. to enter 12.6, enter 1, then 2, then touch the Decimal Point key, and finally enter 6.

To enter numbers less than 1, a zero must be entered before the decimal point; e.g. .07 would be entered as 0.07.

Regardless of the setting of the Decimal Wheel, the complete figure entered on the keyboard will be printed when the Start key or an operation key is touched.

## As it affects OUTPUT PRINTING:

All printed output, except that of the R register, is truncated to the setting of the Decimal Wheel.

## As it affects TRANSFER OPERATIONS:

Regardless of the setting of the Decimal Wheel, the complete figure in the selected register will be transferred.

# Split Register



As was pointed out in the preceding pages, each of the B, C, D, E and F registers can be split into two parts, each with a capacity of 11 digits plus decimal point and sign. The left part of the register is identified with the lower case letter corresponding to its companion's designation. The lower case designation is obtained by entering the corresponding upper case letter and touching the "/" key, e.g. c = C/. The right side of the split register retains its original upper case letter designation.

The computer has built-in self-regulating circuitry that alerts the operator with an error light if an attempt has been made to transfer a value larger than 11 digits to a split register, or to split a register that already contains a value greater than 11 digits.

Nevertheless, a register can be used as both a whole and a split register at varying times throughout a program by using the clear (\*) instruction before shifting from whole to split or vice versa. For example:

In phase one of a program, register B is used as a split register (b,B); then in phase two, register B is to be used as a whole register:

- 1 At the end of phase 1, a B/\* instruction frees the left side of the register so that in phase 2, it can be used in conjunction with the right side as a whole register.
- 2 At the end of phase 2, a B\* instruction frees the whole register so that it can be used as a split register when the program starts again with phase 1.



## Start-S

The instruction "S" (used in creating a program) directs the computer to stop and release the keyboard for the entry of figures or the selection of a subroutine. After figure entry, the program is restarted by touching the Start key (S).

The program can also be restarted by touching a Routine Selection key. When the "S" instruction stops the program, the computer may also be operated in the manual mode without disturbing the program instructions in memory. Any figures entered on the keyboard before depression of Start or an operation key will be printed automatically.



## Clear

The clear operation "\*" directs the computer to clear the selected register. The M and R registers can not be cleared with this instruction.

When the computer is operated manually this key will also cause it to print the contents of the selected register.

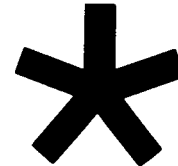

**EXAMPLE:** Assume register B contains 3.14159 prior to the execution of a B\* instruction. After execution of the instruction the register is blank. Note that the contents of other registers are not affected.

	M	A	R	B
BEFORE	5.12	1.00	0.11	3.14159
B *				
AFTER	5.12	1.00	0.11	—

## Print

The print "◇" operation directs the computer to print the contents of the selected register while retaining them in the register. The number of decimal places in the printed result is controlled by the Decimal Wheel.

**EXAMPLE:**

A◇	results	2.71828	A◇
B/◇	results	1.77245	b◇



## Vertical Spacing

The instruction "/◇" directs the computer to advance the tape one vertical space, without printing.



# Data Transfer Operations



## To A

An instruction containing the operation "↓" directs the computer to transfer the contents of the addressed register to A while retaining them in the original register. The contents of M and R are not affected. The previous contents of A are destroyed. The setting of the Decimal Wheel has no effect on this operation.

INSTRUCTION	RESULTS
↓	M → A
R ↓	R → A
A ↓	Inoperative
b ↓	b → A
B ↓	B → A
c ↓	c → A
C ↓	C → A
d ↓	d → A
D ↓	D → A
e ↓	e → A
E ↓	E → A
f ↓	f → A
F ↓	F → A

### EXAMPLE:

Decimal Wheel set at 2.

	M	A	R	B
BEFORE	24	36.05	48.123	12.00
R ↓				
AFTER	24	48.123	48.123	12.00

An example of using this instruction manually to transfer a value entered on the keyboard to the A register would be to enter a figure on the keyboard (e.g. 1.141421) and then depress the ↓ key. After the ↓ key is depressed, the data will be transferred to A and the computer will print the number and the instruction, e.g. 1.141421 ↓. However, if the number had been in a register (e.g. B) and that register were directed to transfer to A, the computer would print only the instruction, e.g. B ↓.

## From M

An instruction containing the operation "↑" directs the computer to transfer the contents of M to the addressed register while retaining them in M. The contents of registers A and R are unaffected by this instruction. The original contents of the addressed register are destroyed. The setting of the Decimal Wheel has no effect on this operation.



INSTRUCTION	RESULT
↑	Inoperative
R ↑	Inoperative
A ↑	See discussion of Constants as instructions
b ↑	M → b
B ↑	M → B
c ↑	M → c
C ↑	M → C
d ↑	M → d
D ↑	M → D
e ↑	M → e
E ↑	M → E
f ↑	M → f
F ↑	M → F

**EXAMPLE:**            Decimal Wheel set at 2.

	M	A	R	B
BEFORE	19.333	5.00	16.00	30.00
B ↑				
AFTER	19.333	5.00	16.00	19.333

An example of using this instruction manually to store a number (e.g. 19.333) in the B register would be to enter 19.333 on the keyboard and then depress the B and ↑ keys. When the ↑ key is depressed, the data will be transferred to B and the computer will print both the number and the instruction executed (e.g. 19.333 B↑). If B/↑ were then manually performed, the same value would be transferred from M to b and the instructions would print on the tape to indicate that the number previously entered was also transferred to b (e.g. b↑).



## Exchange

An instruction containing the operation " $\updownarrow$ " directs the computer to exchange the contents of the A register with the contents of the addressed register. The contents of M are not affected except by the exchange between A and M. The contents of the R register are not affected. The setting of the Decimal Wheel has no effect on this operation.

INSTRUCTION	RESULT
$\updownarrow$	M $\rightleftharpoons$ A
R $\updownarrow$	operates as R $\downarrow$ (R $\rightarrow$ A)
A $\updownarrow$	Absolute Value
b $\updownarrow$	b $\rightleftharpoons$ A
B $\updownarrow$	B $\rightleftharpoons$ A
c $\updownarrow$	c $\rightleftharpoons$ A
C $\updownarrow$	C $\rightleftharpoons$ A
d $\updownarrow$	d $\rightleftharpoons$ A
D $\updownarrow$	D $\rightleftharpoons$ A
e $\updownarrow$	e $\rightleftharpoons$ A
E $\updownarrow$	E $\rightleftharpoons$ A
f $\updownarrow$	f $\rightleftharpoons$ A
F $\updownarrow$	F $\rightleftharpoons$ A

### EXAMPLE:

Decimal Wheel set at 2.

	M	A	R	B
BEFORE	6	9.0014	12.00	15.123
B $\updownarrow$				
AFTER	6	15.123	12.00	9.0014

This instruction can be used manually, however, the computer will print only the addressed register and the instruction. e.g. C  $\updownarrow$ .

## D-R Exchange

The instruction "RS" directs the computer to exchange the contents of D (both D and d registers) with the contents of the R register. The setting of the Decimal Wheel has no effect on this operation.

# RS

This instruction has a special use in the following cases exclusively:

- In multiscard programs, to temporarily store the contents of the D (d,D) register in R, when a new card has to be read to continue the program. During this temporary storage no instruction affecting the R register can be executed.

INSTRUCTION	RESULT
RS	d, D $\neq$ R

**EXAMPLE:** Decimal Wheel set at 2.

	d	D	R
BEFORE	2.25	45.50	135798624211345
RS			
AFTER	135798624211345	2.25	45.50
BEFORE	135798624211345	2.25	45.50
RS			
AFTER	2.25	45.50	135798624211345

- To use the D register for data storage in the second phase of a program when, in the first phase, this register has been used to store instructions which are no longer needed, the RS instruction must be preceded by R \* (usually inoperative).

**EXAMPLE:** Decimal Wheel set at 2.

	d	D	R
BEFORE	Instructions	16.12	
R*			
RS			
AFTER			

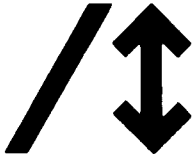

## Decimal Part To M

*The instruction “/↕” directs the computer to transfer the decimal portion of the contents of A to the M register while retaining the entire contents in A. The original contents of the M register are destroyed. The R register is not affected by this instruction. The setting of the Decimal Wheel has no effect on this operation.*

### EXAMPLE:

Decimal Wheel set at 3.

BEFORE



AFTER

M	A	R	B
2.6	5.231	20	18
0.231	5.231	20	18

All arithmetic operations are performed in the operating registers M, A and R. An arithmetic operation is performed in two phases:

- 1 The contents of the selected register are automatically transferred to the M register. The M register is selected automatically if no other register is indicated.
- 2 The operation is carried out in the M, A and R registers.

Programma 101 can perform these arithmetic operations: +, -,  $\times$ ,  $\div$ ,  $\sqrt{\quad}$ , and absolute value. Figures are accepted and computed algebraically. A negative value is entered by depressing the negative key at any time during the entry of a figure. If there is no negative indication, the computer will accept the figure as positive.

The Subtract operation key is separate from the numeric keyboard and is used exclusively for subtraction.

These operations are described in detail in the following pages.

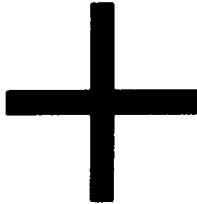

## Addition

An instruction containing the operation “+” directs the computer to add the contents of the selected register (addend) to the contents of the A register (augend) and is executed in two phases:

### 1ST PHASE

*Transfer the contents of the selected register (addend) to M, while retaining them in the original register.*

### 2ND PHASE

*Add the contents of M to the contents of A (augend), obtaining in A the sum truncated according to the setting of the Decimal Wheel. The complete sum is in R. M contains the addend.*

INSTRUCTION	PHASE 1	PHASE 2	RESULTS	
			TRUNCATED	COMPLETE
+		A + M	A	R
R +	R → M	A + M	A	R
A +	A → M	A + M	A	R
b +	b → M	A + M	A	R
B +	B → M	A + M	A	R
c +	c → M	A + M	A	R
C +	C → M	A + M	A	R
d +	d → M	A + M	A	R
D +	D → M	A + M	A	R
e +	e → M	A + M	A	R
E +	E → M	A + M	A	R
f +	f → M	A + M	A	R
F +	F → M	A + M	A	R

### EXAMPLE:

Decimal Wheel set at 2.

	M	A	R	B
BEFORE	5	7.2567	9.00	3.255
B +				
AFTER	3.255	10.51	10.5117	3.255

An example of using this instruction manually to add 2 factors would be:

Enter factor 1 on keyboard and transfer to A Register by

depressing “↓” ..... 1.1532 ↓

Enter factor 2 on keyboard and add to A register by

depressing “+” ..... 16.33236 +

Print sum by depressing key A ◇ ..... 17.48556 A ◇

For this example the Decimal Wheel was set at 5.



## Subtraction

An instruction containing the operation “-” directs the computer to subtract the contents of the selected register (subtrahend) from the contents of the A register (minuend) and is executed in two phases:

**1ST PHASE**                      *Transfer the contents of the selected register (subtrahend) to M, while retaining them in the original register.*

**2ND PHASE**                      *Subtract the contents of M from the contents of A (minuend) obtaining in A the difference truncated according to the setting of the Decimal Wheel. The complete difference is in R. M contains the subtrahend.*

INSTRUCTION	PHASE 1	PHASE 2	RESULTS	
			TRUNCATED	COMPLETE
-		A - M	A	R
R -	R → M	A - M	A	R
A -	A → M	A - M	A	R
b -	b → M	A - M	A	R
B -	B → M	A - M	A	R
c -	c → M	A - M	A	R
C -	C → M	A - M	A	R
d -	d → M	A - M	A	R
D -	D → M	A - M	A	R
e -	e → M	A - M	A	R
E -	E → M	A - M	A	R
f -	f → M	A - M	A	R
F -	F → M	A - M	A	R

**EXAMPLE:**                      Decimal Wheel set at 2.

	M	A	R	B
BEFORE	5	7.2567	9.00	3.255
B -				
AFTER	3.255	4.00	4.0017	3.255

An example of using this instruction manually to subtract 2 factors would be (assume factor 1 (7.2567) is in the b (B/) register and factor 2 (3.255) is in the B register):

Transfer factor 1 to the A register by depressing keys B/↓ ..... b ↓

Subtract the second factor by depressing keys B - ..... B -

Print the difference by depressing A ◇ ..... 4.0017 A ◇

For this example the Decimal Wheel was set at 4.



## Multiplication

An instruction containing the operation "X" directs the computer to multiply the contents of the selected register (multiplicand) by the contents of the A register (multiplier) and is executed in two phases:

### 1ST PHASE

*Transfer the contents of the addressed register to M, while retaining them in the original register.*

### 2ND PHASE

*Multiply the contents of M by the contents of A, obtaining in A the product truncated according to the setting of the Decimal Wheel. The complete product is in R. M contains the multiplicand.*

INSTRUCTION	PHASE 1	PHASE 2	RESULTS	
			TRUNCATED	COMPLETE
X		A X M	A	R
R X	R → M	A X M	A	R
A X	A → M	A X M	A	R
b X	b → M	A X M	A	R
B X	B → M	A X M	A	R
c X	c → M	A X M	A	R
C X	C → M	A X M	A	R
d X	d → M	A X M	A	R
D X	D → M	A X M	A	R
e X	e → M	A X M	A	R
E X	E → M	A X M	A	R
f X	f → M	A X M	A	R
F X	F → M	A X M	A	R

### EXAMPLE:

Decimal wheel set at 2.

	M	A	R	B
BEFORE	5	7.25	9.00	3.25
B X				
AFTER	3.25	23.56	23.5625	3.25

An example of using this instruction manually would be:

Enter the multiplier on the keyboard and transfer to the A register by depressing "↓" ..... 7.25 ↓  
 Enter the multiplicand on the keyboard and depress the "X" key ..... 3.25 X  
 The product will print automatically only when the instruction is performed manually ..... 23.56 A ◊  
 It should be noted that the complete product is available in the R register and will be printed by depressing the keys R ◊ ..... 23.5625 R ◊

## Division

An instruction containing the operation " $\div$ " directs the computer to divide the contents of A register (dividend) by the contents of the selected register (divisor) and is executed in two phases:

- 1ST PHASE**                      *Transfer the contents of the addressed register to M, while retaining them in the original register.*
- 2ND PHASE**                      *Divide the contents of A by the contents of M, obtaining in A the quotient truncated according to the setting of the Decimal Wheel. The decimally correct fractional remainder is in R. M contains the divisor.*

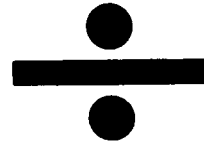

INSTRUCTION	PHASE 1	PHASE 2	QUOTIENT	REMAINDER
$\div$		A $\div$ M	A	R
R $\div$	R $\rightarrow$ M	A $\div$ M	A	R
A $\div$	A $\rightarrow$ M	A $\div$ M	A	R
b $\div$	b $\rightarrow$ M	A $\div$ M	A	R
B $\div$	B $\rightarrow$ M	A $\div$ M	A	R
c $\div$	c $\rightarrow$ M	A $\div$ M	A	R
C $\div$	C $\rightarrow$ M	A $\div$ M	A	R
d $\div$	d $\rightarrow$ M	A $\div$ M	A	R
D $\div$	D $\rightarrow$ M	A $\div$ M	A	R
e $\div$	e $\rightarrow$ M	A $\div$ M	A	R
E $\div$	E $\rightarrow$ M	A $\div$ M	A	R
f $\div$	f $\rightarrow$ M	A $\div$ M	A	R
F $\div$	F $\rightarrow$ M	A $\div$ M	A	R

**EXAMPLE:**                      Decimal wheel set at 2.

	M	A	R	B
BEFORE	5	7.00	9.1234	3.00
B $\div$				
AFTER	3.00	2.33	0.01	3.00

An example of using this instruction manually would be (assume the dividend (7.00) is in the b (B/) register and the divisor (3.00) is in the B register):  
 Transfer the dividend to the A register by depressing keys B/ $\downarrow$  ...      b  $\downarrow$   
 Divide the dividend by the divisor by depressing keys B  $\div$  .....      B  $\div$   
 The quotient will print automatically only when the instruction

is performed manually ..... 2.33 A  $\diamond$   
 It should be noted that the remainder is in the R register and will  
 be printed by depressing the keys R  $\diamond$  ..... 0.01 R  $\diamond$

Decimal Wheel set at 2.

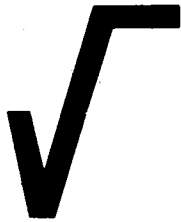

## Square Root

An instruction containing the operation "√" directs the computer to:

1ST PHASE

*Transfer the contents of the selected register to M, while retaining them in the original register.*

2ND PHASE

*Extract the square root of the contents of M, as an absolute value, obtaining in A the result truncated according to the setting of the Decimal Wheel. The R register contains a nonfunctional remainder. At the end of the operation, M contains double the square root.*

INSTRUCTION	PHASE 1	PHASE 2	TRUNCATED RESULT
√		√ M → A	A
R √	R → M	√ M → A	A
A √	A → M	√ M → A	A
b √	b → M	√ M → A	A
B √	B → M	√ M → A	A
c √	c → M	√ M → A	A
C √	C → M	√ M → A	A
d √	d → M	√ M → A	A
D √	D → M	√ M → A	A
e √	e → M	√ M → A	A
E √	E → M	√ M → A	A
f √	f → M	√ M → A	A
F √	F → M	√ M → A	A

EXAMPLE:

Decimal wheel set at 2.

	M	A	R	B
BEFORE	5	7.00	7.00	3.00
B √				
AFTER	3.46	1.73	7.10	3.00

An example of using this instruction manually would be to enter the factor (3) on the keyboard and depress the key √. The extracted root will print automatically only when the instruction is performed manually.

If the factor were in a register (e.g. B), a depression of the keys B √ would instruct the computer to take the square root of the contents of the B register.

3 √  
1.73 A ◇  
B √  
1.73 A ◇

## Absolute Value

The absolute value instruction "A↕" changes the contents of the A register, if negative, to positive.



**EXAMPLE:**

Decimal Wheel set at 2.

	M	A	R	B
BEFORE	3	-6	4	8
A↕				
AFTER	3	6	4	8

# Jump Operations

The Jump operation directs the computer to depart from the normal sequence of step-by-step instructions and jump to a pre-selected point in the program.

These instructions provide both internal and external (manual) decision capability and are useful to:

**Create "loops" that allow repetitive sequences in a program to be executed.**

**Select alternate routines or subroutines at the discretion of the operator.**

**Automatically "branch" to alternate routines or subroutines according to the value in the "A" register.**

The jump operation requires two related instructions:

- 1 Point of origin: where to start the jump, interrupting the sequence.**
- 2 Reference point: where the jump will arrive, restarting the sequence.**

There are two types of jump instructions:

**Unconditional jumps**

**Conditional jumps**

## Unconditional Jumps

these jumps are executed whenever the instruction is read

List of Unconditional Jump Instructions:

	POINT OF ORIGIN	REFERENCE POINT
normally used to initiate program or to select a subroutine manually.	V	AV
	W	AW
	Y	AY
	Z	AZ
	CV	BV
	CW	BW
	CY	BY
	CZ	BZ
	DV	EV
	DW	EW
	DY	EY
	DZ	EZ
	RV	FV
	RW	FW
	RY	FY
	RZ	FZ

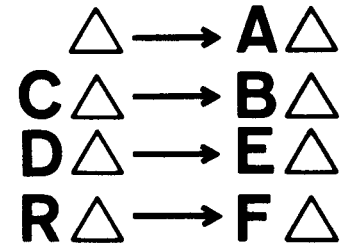

An abbreviated form of this list is to combine V, W, Y or Z as follows:



All programs normally begin with the reference point of an unconditional jump instruction. Reference Points AV, AW, AY, AZ are used so the program sequence can be started simply by touching Routine Selection key V, W, Y or Z. However, any point of origin may be selected from the keyboard.

**EXAMPLE:** Following are illustrative routines reflecting the use of routine selection keys to select a programmed sequence:

Key V → a + b  
 Key W → a - b  
 Key Y → a × b  
 Key Z → a / b

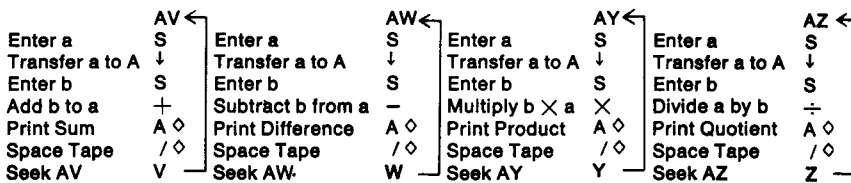

/△ → a △

c △ → b △

d △ → e △

r △ → f △

## Conditional Jumps

these jumps choose one of two alternatives by testing the contents of the A register for the following condition:

If the contents of the A register are:

**GREATER THAN 0** – the program jumps to the corresponding Reference Point.

**ZERO OR LESS** – the program continues with the next instruction in sequence.

List of Conditional Jump Instructions:

POINT OF ORIGIN	REFERENCE POINT
/V	a V
/W	a W
/Y	a Y
/Z	a Z
cV	b V
cW	b W
cY	b Y
cZ	b Z
dV	e V
dW	e W
dY	e Y
dZ	e Z
rV	f V
rW	f W
rY	f Y
rZ	f Z

The lower case letters shown in the above lists are obtained by entering the corresponding upper case letter and touching the “/” key, e.g. r = R/.

An abbreviated form of the above chart is created by combining V, W, Y, Z with the following:

/△ → a △  
c △ → b △  
d △ → e △  
r △ → f △

△ = V, W, Y or Z.



The Conditional Jump can not directly differentiate between a negative value and zero. If the A register has a negative value, the distinction may be made by a two-test procedure: 1. The value of A is tested. If the jump occurs, this value is positive; if the jump does not occur, the A  $\downarrow$  (absolute value) instruction is executed. 2. The value of A is again tested. If the jump occurs, the value is negative. If the jump does not occur the value is zero. If necessary, the program can re-establish the initial algebraic condition of A.

The following sample program is for a simple calculation,  $c = a - b$ , to illustrate conditional jumps by testing for a +, -, or 0 value in the A register.

Starting point of program; reached by touching the key V.	A V
Stop computer to enter value for a.	S
Transfer value a to the A register.	$\downarrow$
Stop computer to enter value for b.	S
Subtract b from a, developing c in the A register.	-
Exchange c to the M register for retention.	$\updownarrow$
Transfer c to the A register for testing.	$\downarrow$
If $c > 0$ jump to A/V.	/ V
If $c < 0$ take absolute value of c.	A $\downarrow$
If $ c  > 0$ jump to B/W.	C/W
If $ c  = 0$ space tape one line.	/ $\diamond$
Return to starting point AV.	V
Entry to routine for $ c  > 0$ .	$\rightarrow$ B/W
Print negative c retained in the M register.	$\diamond$
Return to starting point AV.	V
Entry to routine for $c > 0$ .	$\rightarrow$ A/V
Print positive c in the A register.	A $\diamond$
Return to starting point AV.	V

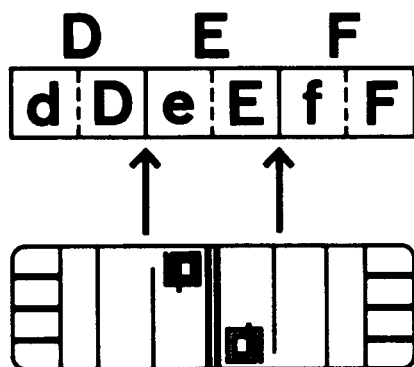

## Constants in Registers

*Programma 101 can store numeric values (e.g. constants) to be used within the program on the magnetic card.*

Numeric values entered into the registers D, E and F, or their splits, can be directly stored together with the program on the magnetic card when the RECORD PROGRAM switch is ON (in). When the card is read, the same values are retrieved from the card and recorded into the original registers.

*This feature provides the capability of storing on the card:*

- up to 3 values of 22 digits each; or
- up to 6 values of 11 digits each (or any combination thereof).

When program instructions overflow from F to D, values can be stored only in those registers, or their splits, not occupied with instructions. This method is primarily useful for values with many digits and/or repeatedly utilized throughout the program.

Having keyed in a program from the keyboard or having loaded a program from a magnetic card:

- 1 Check that the RECORD PROGRAM and PRINT PROGRAM switches are OFF (out).
- 2 Enter the constant figures that are to be stored and transfer them to their appropriate registers.  
**EXAMPLE:** to store - 17.366 in the f register, depress keys -, 1, 7, ., 3, 6, 6 in succession; touch keys F/↑ in order. The constant - 17.366 is now stored in the f register.
- 3 Repeat this procedure for each constant to be stored. After all constants have been transferred to their appropriate registers, to store the program and the new constants permanently, turn RECORD PROGRAM switch ON (in) and insert the magnetic card into the computer. The program and the contents of registers d, D, e, E, f and F are now recorded on the magnetic card for subsequent use.

## Constants as Instructions



It is sometimes necessary to conserve registers for several accumulations and, therefore, advisable to avoid storing constants in these registers. There is a method for generating values within a program by converting the required number into computer instructions, one for each digit.

These instructions are preceded by the instruction  $a^\uparrow$  ( $A/\uparrow$ ) and are entered as part of the program.

When the computer carries out this special series of instructions, the value is generated in the M register.

Before recording the program, the programmer generates the instructions for the required value in the following manner:

- 1 Turn PRINT PROGRAM switch ON (in).
- 2 Turn RECORD PROGRAM switch OFF (out).
- 3 Touch GENERAL RESET.
- 4 Enter the value to be generated.
- 5 Touch the Keys  $A^\uparrow$ .

Repeat steps 3 through 5 for each value.

The computer will print the sequence of instructions that corresponds to the entered value. Then the programmer enters these instructions as a part of the program, following the special instruction  $a^\uparrow$  ( $A/\uparrow$ ); the special instruction must precede each value generated within the program.

This method is primarily useful for values with few digits and/or utilized only once within a program routine.

The following chart may be useful in writing constants into a program without utilizing the Programma to convert the constant into instruction form.

R Positive digit	S	0
D Positive hi-order digit	↓	1
F Negative digit	↑	2
E Negative hi-order digit	↕	3
/ decimal point, (included with units position of the integer)	+	4
	-	5
	×	6
	÷	7
	◇	8
	*	9

**EXAMPLE:** to generate 31.68 within a program the instructions would be:

- $A/\uparrow$  To start special series of instructions  
 R ◇ 8  
 R × 6  
 R/↓ 1.  
 D ↕ 3 and to terminate special series of instructions.

Note that the value is generated starting with the least significant digit. The decimal locator (1) is included with the instruction creating the units position of the integer.



## Read/Record D and E

*Constants and instructions:* 1) can be entered from the keyboard directly into registers E and D; 2) can be recorded from only registers E and D onto a card; or; 3) read from a card only into registers E and D, *without affecting the contents of other program registers*. This technique can be utilized most effectively for the creation and use of subroutine or module programs.

- 1 To enter instructions from the keyboard directly into registers E and D, completely by-passing instruction registers 1 and 2, and storage register F:  
Turn computer ON;  
Touch GENERAL RESET;  
Turn RECORD PROGRAM switch ON (in);  
Turn PRINT PROGRAM switch ON (in);  
Enter, in order, the instructions that comprise the subroutine or modular program;  
The instructions will be received first by E, then e, then D, then d (if the maximum capacity of 48 instructions are utilized).
- 2 If the information in the D and E registers is to be recorded onto a magnetic card:  
BOTH the RECORD PROGRAM switch and the PRINT PROGRAM switch must be ON (in);  
Insert magnetic card;  
The transfer of information will be from the D and E registers of the memory to the program card.
- 3 If the contents of a card are to be read only into the D and E registers: The PRINT PROGRAM switch is turned ON (in) and the program card is inserted;  
Information is read into the D and E registers exclusively;  
The contents of the other registers are unaffected.

## To Print a Program

Once a program has been recorded on a magnetic card, the entire sequence of instructions forming the program can be printed out. This is normally used to analyze a new program to insure correct entry, or to locate an error in the program.

- 1 To locate the initial instruction of a program, insert the program card.
- 2 Turn PRINT PROGRAM ON (in); touch the Print key (◇).
- 3 The computer will print the instructions in their programmed sequence.
- 4 The computer will stop at each Stop (S) instruction. To continue the printing of the instructions, touch the Print key (◇).
- 5 When the entire program has been printed, turn PRINT PROGRAM OFF (out).

To locate an error within a program, after the Error light has gone on, follow steps 2 through 5 above. This prints the instructions from the present location in the program. The instruction immediately preceding the first printed instruction caused the activation of the Error light.

## To Use a Program

- 1 Turn computer ON.
- 2 Touch GENERAL RESET.
- 3 Turn RECORD PROGRAM and PRINT PROGRAM switches OFF (out).
- 4 Set DECIMAL WHEEL to desired position.
- 5 Insert the program card into the computer. The program card can be removed from the computer at any time, since the program is transferred directly to the memory. If the program is to be repeated, the program card need not be reinserted since the program remains in the computer.
- 6 Depress the proper ROUTINE SELECTION key.
- 7 Operations will occur as explained in the operating procedure. The keyboard will lock during computations. When variable factors are to be entered, the program will stop and the keyboard will be unlocked to permit data entry.

## Automatic Internal Checks

Programma 101 provides a system of automatic internal checks to assure the operator that all components are functioning properly. The red ERROR light is the visual indication that a mis-operation has been detected.

When a magnetic program card is misread, the error indicated is usually either the result of a damaged or dirty card, or the improper insertion of the card.

*examine the physical condition of the card and if there is no evidence of damage, reinsert the card properly.*

The following mis-operations are indicated by the Error light:

- Capacity exceeded by computation.  
The original contents of registers A and R are destroyed.
- Capacity of a split register exceeded by a transfer.  
The transfer is not performed.
- Division by zero.
- Keyboard entry capacity exceeded.  
To repeat the entry correctly, the clear entry key must first be depressed.
- An erroneous attempt has been made to store data and instructions in the same register. (See discussion of storage of data and instructions in the same register).

*the following steps provide the information basic to the analysis of the above errors:*

- *print out all registers*
- *print out program from point of error (the instruction immediately preceding the first printed instruction is the operation that caused the error)*
- *print out the complete program*

**Programma 101 can be operated manually as an electronic calculator. The rules given in the preceding pages for computer instructions apply also to manual operations with the following exceptions:**

- 1 The results of multiplication, division and square root will be printed automatically.**
- 2 The results of addition and subtraction will be printed only by touching the keys A and  $\diamond$  in sequence.**
- 3 The \* key when touched will cause both printing and clearing of the selected register (except M and R).**

**The computer can also be operated manually, while it is being used in program mode, at any stop instruction in the program. In this case, the operator should be careful when entering figures in the registers not to affect the contents of the registers used by the program.**

# Computer Exercise

The following exercise shows you how to:

- use the Programma manually
- write a program

The problem used is:

$$a + b = \text{ans.}$$

$$a - b = \text{ans.}$$

$$a \times b = \text{ans.}$$

$$a \div b = \text{ans.}$$

$$\sqrt{a} = \text{ans.}$$

grand total (GT)

Assume  $a = 9$  and  $b = 3$ ;

The following operations solve the problem manually:

Turn the computer ON.

Depress the GENERAL RESET key.

Turn the RECORD PROGRAM switch OFF (out).

Turn the PRINT PROGRAM switch OFF (out).

Set DECIMAL WHEEL to desired number.

Enter  $a$  and Transfer to B/.

Enter  $b$  and Transfer to B.

Move 9 (B/) to A register.

Add 3 (B) to 9 (A).

Print answer in A.

Transfer answer to (C).

Move 9 (B/) to A register.

Subtract 3 (B) from 9 (A).

Print answer in A.

Add answer (A) and GT (C).

Store new GT in C.

Move 9 (B/) to A register.

Multiply 3 (B)  $\times$  9 (A).

Answer prints automatically.

Add answer (A) and GT (C).

Store GT in C.

Move 9 (B/) to A register.

Divide 3 (B) into 9 (A).

Answer prints automatically.

Add answer (A) and GT (C).

Store new GT in C.

Take square root of 9 (B/).

Answer prints automatically.

Add answer (A) and GT (C).

Store new GT in C.

Print GT.

Programma prints

9 b  $\uparrow$   
 3 B  $\uparrow$   
 b  $\downarrow$   
 B +  
 12 A  $\diamond$   
 C  $\updownarrow$   
 b  $\downarrow$   
 B -  
 6 A  $\diamond$   
 C +  
 C  $\updownarrow$   
 b  $\downarrow$   
 B  $\times$   
 27 A  $\diamond$   
 C +  
 C  $\updownarrow$   
 b  $\downarrow$   
 B  $\div$   
 3 A  $\diamond$   
 C +  
 C  $\updownarrow$   
 b  $\sqrt{\phantom{x}}$   
 3 A  $\diamond$   
 C +  
 C  $\updownarrow$   
 51 C  $\diamond$



**PROGRAM FORM**

NO	INSTRUCTIONS	M
	A V	
	C X	
	S	
B /	↑	
	S	
B ↑		
B /	↓	
B +		
A	◇	
C	↕	
B /	↓	
B -		
A	◇	
C +		
C	↕	
B /	↓	
B X		
A	◇	
C +		
C	↕	
B /	↓	
B ÷		
A	◇	
C +		
C	↕	
B /	√	
A	◇	
C +		
C	↕	
C	◇	
	V	

The following instructions solve the same problem in program mode:

- Starting Point of Program.
- Clear register for accumulation of answers.
- Stop program for entry of factor a.
- Transfer factor a to B /.
- Stop program for entry of factor b.
- Transfer factor b to B.
- Transfer factor a to A register.
- Add factor B to factor a in A register.
- Print answer in A register.
- Transfer answer to C register (GT).
- Transfer factor a to A register.
- Subtract factor b from factor a in A register.
- Print answer in A register.
- Add answer and GT (C register).
- Transfer new GT to C register.
- Transfer factor a to A register.
- Multiply factor b X a.
- Print answer in A register.
- Add answer and GT (C register).
- Transfer new GT to C register.
- Transfer factor a to A register.
- Divide factor b into factor a.
- Print answer in A register.
- Add answer and GT (C register).
- Transfer new GT to C register.
- Take square root of factor a.
- Print answer in A register.
- Add answer and GT (C register).
- Transfer new GT to C register.
- Print Final GT in C register.
- Jump to Start of Program.

*Note that the manual solution to the problem and the programmed solution are quite similar, with exceptions only for the instructions to create the loop, and the entry of variables. Consequently, a useful technique for testing and debugging a new program is the step-by-step manual operation of the written sequence.*

# Changing The Ribbon

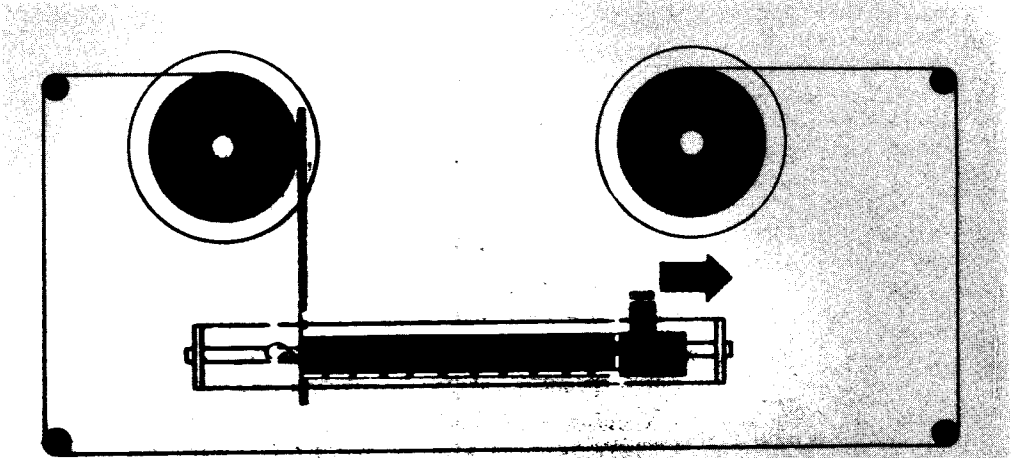

- 1 Remove print unit cover and pull paper tape holder forward.
- 2 Move the ribbon reverse levers away from the spools (see diagram).
- 3 Remove spools and ribbon and discard.
- 4 Replace the spools and thread the ribbon as indicated in the diagram. Restore the ribbon reverse levers.

# Insertion of Paper Roll

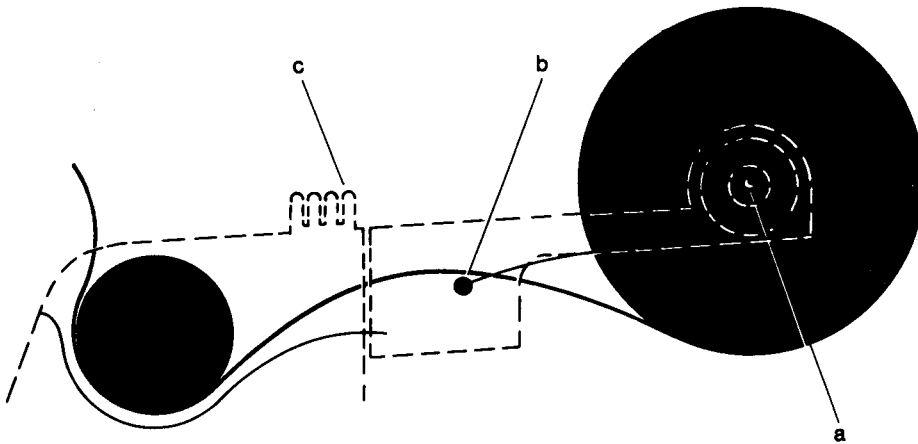

- 1 Remove the paper roll bar (a) and discard the old spool.
- 2 Place the new roll between the two holders, so the tape feeds from underneath, and insert paper roll bar.
- 3 Turn Programma on.
- 4 Feed the tape over the guide bar (b) and under the print cylinder. Depress the tape advance lever (c) to feed tape through the printing unit.
- 5 Depress tape release lever to adjust tape alignment.

# Programming Techniques

Following are some frequently encountered mathematical statements and suggested Programma solutions, assuming the value  $a$  is in the A register:

- $(a + 1)$      $A \div$  Divide  $a$  by itself creating 1 in the A register.  
              + Add  $a$  to 1 giving  $(a + 1)$
- $(a - 1)$      $A \div$  Divide  $a$  by itself creating 1 in the A register.  
               $\updownarrow$  Exchange the contents of M ( $a$ ) and the contents of A (1).  
              - Subtract 1 from  $a$  giving  $(a - 1)$ .
- $(1 - a)$      $A \div$  Divide  $a$  by itself creating 1 in the A register.  
              - Subtract  $a$  from 1 giving  $(1 - a)$ .
- $a(1 + a)$      $A \times$  Multiply  $a$  by itself giving  $a^2$  in the A register.  
              + Add  $a$  (from M) to  $a^2$  giving  $(a^2 + a)$  which is equal to  $a(1 + a)$
- $a(a - 1)$      $A \times$  Multiply  $a$  by itself giving  $a^2$ .  
              - Subtract  $a$  from  $a^2$  giving  $(a^2 - a)$  which is equal to  $a(a - 1)$
- $a(1 - a)$      $A \times$  Multiply  $a$  by itself giving  $a^2$ .  
               $\updownarrow$  Exchange the contents of M ( $a$ ) with the contents of A ( $a^2$ ).  
              - Subtract  $a^2$  from  $a$  giving  $(a - a^2)$  which is equal to  $a(1 - a)$ .

## Rounding Techniques

Following are routines for rounding to the setting of the Decimal Wheel in addition, subtraction and multiplication. Assume one value is stored in the B register and the second value in the C register:

ADDITION	SUBTRACTION	MULTIPLICATION	
B ↓	B ↓	B ↓	Transfer first value to A register.
C +	C -	C ×	Perform operation.
R -	R -	R -	Subtract complete result from truncated result.
↓	↓	↓	Transfer complete result to A register.
R -	R -	R -	Subtract negative remainder from complete result.
A ◇	A ◇	A ◇	Print rounded result.

Following are techniques for rounding the Quotient in a division problem to the setting of the Decimal Wheel:

### METHOD 1:

Assume the divisor is in register B and the dividend is in register C.

- C ↓ Transfer dividend to A register.
- B ÷ Divide dividend by divisor.
- R ↓ Transfer remainder to A register.
- C + Add dividend to remainder.
- R ↓ Transfer decimally correct dividend + remainder to A register.
- B ÷ Divide dividend + remainder by divisor.
- A ◇ Print rounded Quotient.

This routine requires 7 instructions.

**METHOD 2:**

Assume the divisor is in register B and the dividend is in register A.

- A + Double dividend.
- B ÷ Divide doubled dividend by the divisor.
- A / ↑ } Special series to generate 2 in
- D / ↑ } the M register.
- ÷ Divide doubled quotient by 2.
- R + Round off.
- A ◇ Print rounded quotient.

This routine requires 7 instructions.

Following is a technique for rounding to some position lower than the setting of the Decimal Wheel, e.g., round to 2 places when the Decimal Wheel is at 5. At the point where the routine begins, assume the operation has been completed and the value to be rounded is in the A register.

- D / × Multiply the contents of the A register by  $10^2$  to shift decimal.
- / ↓ Transfer the decimal portion of the contents of A to M:
- + Add decimal portion to contents of A.
- / ↓ Transfer the decimal portion of the contents of A to M.
- Subtract decimal portion from the contents of A.
- D / ÷ Divide the contents of the A register by  $10^2$  to shift the decimal.
- A ◇ Print rounded answer.

This routine requires 7 instructions and 1 register containing a constant  $10^n$  where n is equal to the position to which rounding is desired.

## Instruction—Data Storage

**Storage of data and instructions in the same half of a register.** A technique has been developed which allows the storage of both a number and program instructions in the same half of a register (F, f, E, e, D, d). This technique permits the programmer to address a register having both a number and instructions in it, and perform any transfer, arithmetic, print or clear operation with the number — without disturbing the instructions in that register and without getting an error light. The number, which may be either a constant or accumulation, must precede the instructions and must not exceed the space allotted for it. For this purpose, the registers should be considered as 24 digit registers with the upper half (F, E, D) containing positions 1-12 and the lower half (f, e, d) containing positions 13-24. A two digit number in the upper half of a register would thus occupy positions 1 and 2. A two digit number in the lower half would occupy positions 13 and 14.

The procedure for storing both program instructions and a number in the same half of a register (F, f, E, e, D, d) is as follows:

- 1 Instructions are keyed into the computer in the usual manner, except that if it is decided to use a portion of a half-register for the storage of a constant or an accumulation, an S should be entered in the program for each digit in the constant or anticipated accumulation.
  - 2 To use the LOWER HALF of a register (f, e, d) in this manner there *must* be a 'signal stop' (an S) in the 12th position of the register concerned (see Fig. 1).
- To use the UPPER HALF of a register (F, E, D) in this manner there *must* be a 'signal stop' (an S) in the 24th position of the register concerned (see Fig. 2).

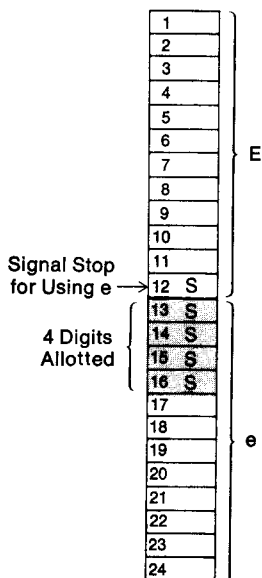

Fig. 1

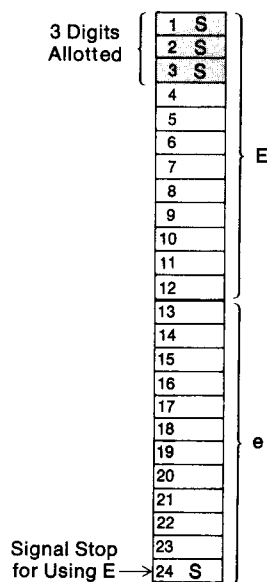

Fig. 2

3 The instruction immediately following the space allotted for the number *must* be either a stop (an S) (see Fig. 3) or an A reference point (AV, AW, AY, AZ, aV, aW, aY, or aZ) (see Fig. 4).

Unless it is a 'signal stop,' there is no restriction on the instruction immediately preceding the space allotted for the number. Normally it would be an origin point to enable the program to skip around the number and continue with subsequent instructions. Similarly, the instruction immediately following the space allotted for the number would be an A reference point or a stop followed by any reference point. (see Figs. 3 and 4).

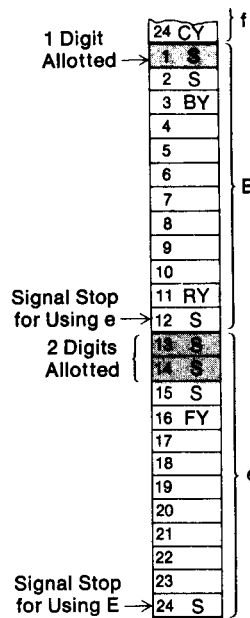

Fig. 3

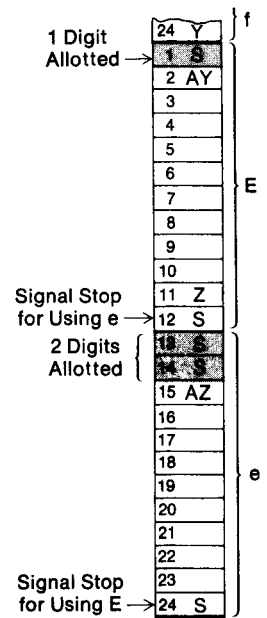

Fig. 4



## Generation of Constants

Following is a routine to generate a constant to the setting of the Decimal Wheel, e.g., with the Decimal Wheel at 4 generate constant 0.0003:

A/ ↑ }  
D/ ↓ } Special series to generate constant 3 in the M register  
↓  
Transfer 3 to A register.  
A/ ↑ }  
D/ \* } Special series to generate constant 9.  
÷  
R ↓  
A ◇ Print generated constant.

Following is a routine to generate a constant to one position more than the setting of the Decimal Wheel, e.g., with the Decimal Wheel at 4 generate constant 0.00005:

A/ ↑ }  
D/ - } Special series to generate 5 in the M register.  
↓  
Transfer 5 to A register.  
A/ ↑ }  
R \* } Special series to generate 0.9 in the M register.  
D/ S }  
÷  
R ↓  
A ◇ Print generated constant.

## Counters

When programming a loop that is to be cycled a specified number of times, the most direct way of accomplishing this is to use one register as a counter, which initially has an index stored in it. This index is reduced by 1 each time the loop is cycled. When the count reaches 0 we may exit the loop. Two examples are shown below:

### Counter to exit on the $k^{\text{th}}$ cycle

Assume  $k$  is initially in register  $C$

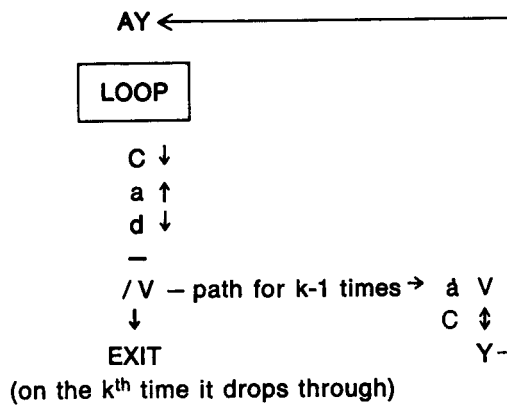

k = 6	
cycle	test value
1	5
2	4
3	3
4	2
5	1
6	0 = Exit

### Counter to exit on the $(k + 1)^{\text{th}}$ cycle

Assume  $k$  is initially in register  $C$

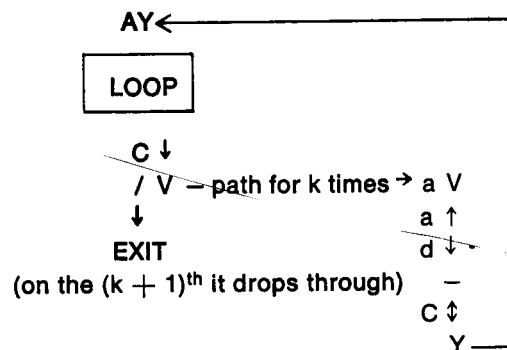

k = 6	
cycle	test value
1	6
2	5
3	4
4	3
5	2
6	1
7	0 = Exit

## Packing a Register

This routine illustrates the concept of "packing" a register. Frequently, it becomes necessary to store a group of constants in just one register. The following routine exemplifies how each of the constants might be stored in one register and isolated for manipulation. Let us assume that we wish to store the constants .453, .281, .397, and .024 all in one register. This can be accomplished by creating the compound number 453281397.024 and storing it in the D register. Note that each of the constants must have the same number of digits. The generated number 1000 will enable us to isolate each of the three digit constants contained within the compound number.

Set decimal wheel to 3.

A V  
D ↓ Bring compound number to A.  
A/ ↑  
R/ S }  
R S } Generate the constant 1000  
R S } in the M register.  
D ↓  
÷ Divide.  
D ⇕ Store remaining portion of compound number in D.  
R ↓ Isolated number to A.  
S Enter some factor.  
× Multiply.  
A ◇ Print result.  
/ ◇ Vertical up space.  
Return to AV.

## The Domino Technique

This program illustrates a procedure referred to as "the domino technique." This technique is particularly useful in applications such as a moving average in which the entry of each subsequent value displaces the contents of every register in the sequence like a row of dominoes. Consider, for example, this program for a moving average where  $N = 5$ .

A V	/ $\diamond$	C / $\updownarrow$
A / $\uparrow$ } generate	S enter $n_5$	C / $\downarrow$
D / - } N = 5	↓	B $\div$
B $\uparrow$	E $\updownarrow$ } domino	R $\downarrow$ } rounding
S enter $n_1$	E / $\updownarrow$ } technique*	C / + } in division
D / $\uparrow$	D $\updownarrow$	B $\div$
S enter $n_2$	D / $\updownarrow$	A $\diamond$
D $\uparrow$	C $\updownarrow$	C V return to BV
S enter $n_3$	E ↓	
E / $\uparrow$	E / +	
S enter $n_4$	D +	
E $\uparrow$	D / +	
B V	C +	

Graphically the domino technique would appear as follows:

	M	A	R	b	B	c	C	d	D	e	E	f	F
enter $n_5$	$n_5$							$n_1$	$n_2$	$n_3$	$n_4$		
↓	M	A	R	b	B	c	C	d	D	e	E	f	F
	$n_5$	$n_5$						$n_1$	$n_2$	$n_3$	$n_4$		
E $\updownarrow$	M	A	R	b	B	c	C	d	D	e	E	f	F
	$n_5$	$n_4$						$n_1$	$n_2$	$n_3$	$n_5$		
E / $\updownarrow$	M	A	R	b	B	c	C	d	D	e	E	f	F
	$n_5$	$n_3$						$n_1$	$n_2$	$n_4$	$n_5$		
* D $\updownarrow$	M	A	R	b	B	c	C	d	D	e	E	f	F
	$n_5$	$n_2$						$n_1$	$n_3$	$n_4$	$n_5$		
D / $\updownarrow$	M	A	R	b	B	c	C	d	D	e	E	f	F
	$n_5$	$n_1$						$n_2$	$n_3$	$n_4$	$n_5$		
C $\updownarrow$	M	A	R	b	B	c	C	d	D	e	E	f	F
	$n_5$						$n_1$	$n_2$	$n_3$	$n_4$	$n_5$		

## Chaining

Occasionally, a program might be required which exceeds 120 instructions (the internal instruction capacity of Programma). Since only five of Programma's ten registers are recorded on a magnetic card, there are five registers available for the storage of as many as eight intermediate results requiring further processing. The procedure for 'chaining' program cards requires that the program be "segmented" at some convenient point and that all significant intermediate results be stored in M, A, R, B and C before concluding the first phase of the program. Assume for example that we have intermediate results in the following registers requiring further processing.

### BEFORE

M	A	R	b	B	c	C	d	D	e	E	f	F
							$\Sigma x$	$\Sigma y$	$\Sigma x^2$	$\Sigma y^2$	$\Sigma xy$	n

A Z A set of instructions similar to those which appear on this  
 R S page would be added to the program so that the operator,  
 E / ↓ having entered all x and y values, would depress the key Z  
 B / ↓ which would initialize a series of transfer operations to  
 E ↓ store intermediate results between cards.  
 B ↓  
 F / ↓  
 C / ↓  
 F ↓  
 C ↓  
 S

### AFTER

M	A	R	b	B	c	C	d	D	e	E	f	F
		$\Sigma x \Sigma y$	$\Sigma x^2$	$\Sigma y^2$	$\Sigma xy$	n						

A V The first series of instructions of the subsequent card must  
 R S incorporate an RS instruction to transfer the contents of R  
 ... back to registers D and d prior to any arithmetic operation  
 ... or reference to the R register.

On the following pages is a typical program from the Olivetti Underwood program library which illustrates many of the techniques described previously.

Least Square's Fit to a  
Parabolic Function

$$y = ax^b$$

DATE	CODE			NO. OF SIDES	NO. OF INSTRUCTIONS					
5/67	4	5	1	5	2	0	3	1	8	2

PROGRAM DESCRIPTION

**olivetti**  
**underwood**  
Programma  
101

This program will perform an unweighted least square's fit to a parabolic function:

$$y = ax^b$$

given as input a set of  $X_i, Y_i$  pairs.

The program consists of three sides of a card and will yield the following information:

- SIDE A -

INPUT:

$X_i, Y_i$

$X_i > 1$

OUTPUT:

n R ◊

$\Sigma \text{Log} X$  b ◊

$\Sigma (\text{Log} X)^2$  c ◊

$\Sigma \text{Log} Y$  B ◊

$\Sigma \text{Log} X \text{ Log} Y$  C ◊

$\Sigma (\text{Log} Y)^2$  D ◊

- SIDE B -

(CONTINUATION OF SIDE A)

OUTPUT:

Log a d ◊

b E ◊

correlation coefficient,  $r_{\text{Log} X; \text{Log} Y}$  A ◊

standard error of estimate,  $S_{\text{Log} X; \text{Log} Y}$  A ◊

Least Square's Fit to a  
Parabolic Function

$$y = ax^b$$

DATE	CODE			NO. OF SIDES	NO. OF INSTRUCTIONS
5/67	4:5	1:5	2:0	3	1:8:2

**PROGRAM DESCRIPTION**

- SIDE C -  
(INTERCEPTS FOR PLOTTING THE FUNCTION  
ON LOG - LOG PAPER)

INPUT:

Log<sub>k</sub>a } from any curve  
b } desired

OUTPUT:

a (Intercept with X = 1)

a<sup>-1/b</sup> (Intercept with Y = 1)

if k = 10 then (E) = Log<sub>e</sub> 10 = 2.3025 850930  
k = e then (E) = 1

Unless altered, the program computes all logarithms to the base 10.

FORMULAS:

PARAMETERS

$$\text{Log } a = \frac{\sum \text{Log} Y \sum (\text{Log} X)^2 - \sum \text{Log} X \text{Log} Y \sum \text{Log} X}{n \sum (\text{Log} X)^2 - (\sum \text{Log} X)^2}$$

$$b = \frac{n \sum \text{Log} X \text{Log} Y - \sum \text{Log} Y \sum \text{Log} X}{n \sum (\text{Log} X)^2 - (\sum \text{Log} X)^2} = \frac{s}{\Delta}$$

CORRELATION COEFFICIENT

$$r_{\text{Log} X \cdot \text{Log} Y} = \frac{s}{\sqrt{\Delta [n \sum (\text{Log} Y)^2 - (\sum \text{Log} Y)^2]}}$$

STANDARD ERROR OF ESTIMATE

$$s_{\text{Log} X \cdot \text{Log} Y} = \sqrt{\frac{\sum [\text{Log} Y - (\text{Log} a + b \text{Log} X)]^2}{n}}$$

$$= \sqrt{\frac{1}{n} \left[ \sum (\text{Log} Y)^2 - 2 \text{Log} a (\sum \text{Log} Y) - 2b (\sum \text{Log} X \text{Log} Y) + n (\text{Log} a)^2 + 2b \text{Log} a (\sum \text{Log} X) + b^2 \sum (\text{Log} X)^2 \right]}$$

Least Square's Fit to a  
Parabolic Function:  
 $y = ax^b$

DATE	CODE	NO. OF SIDES	NO. OF INSTRUCTIONS
5/67	4 5 1 5 2 0	3	1 8 2

### PROGRAM INSTRUCTIONS

SIDE NO. A

REG. 1	REG. 2	REG. F	REG. E	REG. D	CONTENTS OF REGISTERS
1 AV	25 /V	49 R/↓	73	97	M Operand
2 S	26 B/↓	50 AY	74	98	A Operand
3 ↓	27 D/+	51 F/↓	75	99	
4 A✓	28 B/↓	52 F+	76	100	R Operand
5 A✓	29 ↓	53 F/↓	77	101	
6 A✓	30 AX	54 V	78	102	$b \sum \text{Log} X$
7 A✓	31 C/+	55 AZ	79	103	
8 A✓	32 C/↓	56 F/↓	80	104	B $\sum \text{Log} Y$
9 A✓	33 V	57 Fx	81	105	
10 A✓	34 A/V	58 R∅	82	106	$c \sum (\text{Log} X)^2$
11 A✓	35 ↓	59 W	83	107	
12 A✓	36 D/x	60 S	84	108	C $\sum \text{Log} X \text{Log} Y$
13 A✓	37 C+	61 S	85	109	
14 F+	38 C↓	62 S	86	110	d Variable
15 E/↓	39 D/↓	63 AW	87	111	
16 E/↓	40 B+	64 B/∅	88	112	D $\sum (\text{Log} Y)^2 \mid n (\text{Log} Y)^2$
17 -	41 B↓	65 C/∅	89	113	
18 -	42 D/↓	66 B∅	90	114	e Variable
19 E/÷	43 Ax	67 C∅	91	115	
20 A+	44 D+	68 D∅	92	116	E 444.7175495
21 Ex	45 D↓	69 RS	93	117	
22 D/↓	46 D/*	70 F/↓	94	118	f $n$ (IDS)
23 A+	47 /∅	71 /∅	95	119	
24 A↓	48 Y	72 S	96	120	F 1 (IDS)
REG. 1	REG. 2	REG. f	REG. e	REG. d	

Lower case letters are entered with the corresponding upper case letters and /; e.g., b=B/.

CONSTANTS ON CARD	KEYS TO TOUCH	CONSTANTS ON CARD	KEYS TO TOUCH
1 (IDS)	F ↑		
$1024 \text{Log}_{10} e \doteq 444.7175495$	E ↑		



Least Square's Fit to a  
Parabolic Function  
 $y = ax^b$

DATE	CODE	NO. OF SIDES	NO. OF INSTRUCTIONS
5/67	451520	3	182

**PROGRAM INSTRUCTIONS**

SIDE NO. B

REG. 1	REG. 2	REG. F	REG. E	REG. D	CONTENTS OF REGISTERS
1 F↓	25 Ax	49 S	73	97	M Operand
2 B/↓	26 D↓	50 S	74	98	
3 Ax	27 Fx	51 AY	75	99	A Operand
4 E/↓	28 D↓	52 B/↓	76	100	
5 C/↓	29 D-	53 D/x	77	101	R Operand
6 Fx	30 E/x	54 Ex	78	102	
7 E/-	31 A✓	55 A+	79	103	b Variable
8 E/↓	32 ↓	56 B/+	80	104	
9 C↓	33 E↓	57 D↓	81	105	B Variable
10 B/x	34 ÷	58 F÷	82	106	
11 E↓	35 E↓	59 D+	83	107	c Variable
12 C/↓	36 E/÷	60 B↓	84	108	
13 Bx	37 E↓	61 D/x	85	109	C Variable
14 E-	38 D/∅	62 A+	86	110	
15 E/÷	39 E∅	63 C↓	87	111	d Loga
16 D/↓	40 A∅	64 Ex	88	112	
17 B/↓	41 D/↓	65 A+	89	113	D Variable
18 Bx	42 Ax	66 C+	90	114	
19 E↓	43 Fx	67 B-	91	115	e Δ
20 C↓	44 C/↓	68 F÷	92	116	
21 Fx	45 Ex	69 A✓	93	117	E s b
22 E-	46 x	70 A∅	94	118	
23 E↓	47 C/+	71 /∅	95	119	f Instructions
24 B↓	48 Y	72 S	96	120	F n (IDS)
REG. 1	REG. 2	REG. f	REG. e	REG. d	

Lower case letters are entered with the corresponding upper case letters and /; e.g., b=B/.

CONSTANTS ON CARD	KEYS TO TOUCH	CONSTANTS ON CARD	KEYS TO TOUCH

Least Square's Fit to a  
Parabolic Function  
 $y = ax^b$

DATE	CODE	NO. OF SIDES	NO. OF INSTRUCTIONS
5/67	4:5 1:5 2:0	3	1:8:2

**PROGRAM INSTRUCTIONS**

SIDE NO. C

REG. 1	REG. 2	REG. F	REG. E	REG. D	CONTENTS OF REGISTERS
1 AV	25 /V	49	73	97	M Operand
2 /o	26 B↓	50	74	98	
3 B/*	27 B/↑	51	75	99	A Operand
4 S	28 /Y	52	76	100	
5 ↓	29 S	53	77	101	R Operand
6 Ex	30 F↓	54	78	102	
7 AY	31 ÷	55	79	103	b $a^{-1/b}$
8 C↑	32 Cx	56	80	104	
9 B*	33 Y	57	81	105	B Variable
10 D*	34 A/Y	58	82	106	
11 A/↑	35 /o	59	83	107	c -
12 D/↓	36 Ao	60	84	108	
13 A/V	37 B/o	61	85	109	C Variable
14 ↓	38 V	62	86	110	
15 B↑	39	63	87	111	d -
16 B+	40	64	88	112	
17 B↑	41	65	89	113	D Variable
18 Cx	42	66	90	114	
19 D↑	43	67	91	115	e -
20 F-	44	68	92	116	
21 D↑	45	69	93	117	E 2.3025850930
22 D÷	46	70	94	118	
23 A+	47	71	95	119	f -
24 A↑	48	72	96	120	
REG. 1	REG. 2	REG. f	REG. e	REG. d	F -1 (IDS)

Lower case letters are entered with the corresponding upper case letters and /; e.g., b=B/.

CONSTANTS ON CARD	KEYS TO TOUCH	CONSTANTS ON CARD	KEYS TO TOUCH
-1	F ↑		
$\log_e 10 \doteq 2.3025850930$	E ↑		

Least Square's Fit to a  
Parabolic Function  
 $y = ax^b$

DATE	CODE			NO. OF SIDES	NO. OF INSTRUCTIONS					
5/67	4	5	1	5	2	0	3	1	8	2

**OPERATING PROCEDURE**

	OPERATIONS	DIGIT CAPACITY		EXAMPLE AND/OR REMARKS	
		DECIMAL WHEEL SETTING 7 - 10	WHOLE NOS.		
1	Depress General Reset Key				
2	Turn Record Program OFF			X 3.075 S	9.760 S
3	Turn Print Program OFF			Y 2.33 S	0.46 S
4	Insert Side A of Program Card			2.350 S	17.5 S
				2.27 S	0.39 S
5	Depress V			2.450 S	4.000 S
				1.97 S	1.40 S
6	Enter $X_i$ and Depress Start				4.200 S
7	Enter $Y_i$ and Depress Start			2.550 S	1.25 S
				1.82 S	
8	Return to Step 6 until data is exhausted. Then go to Step 9.				4.750 S
				5.05 S	1.25 S
				1.32 S	
9	Depress Z				5.170 S
10	Computer prints:			4.100 S	1.07 S
	n R0			1.05 S	
	$\Sigma \text{Log} X$ b0				5.800 S
	$\Sigma (\text{Log} X)^2$ c0			8.500 S	1.05 S
	$\Sigma \text{Log} Y$ B0			0.80 S	
	$\Sigma \text{Log} X \text{Log} Y$ C0				
	$\Sigma (\text{Log} Y)^2$ D0				
11	Without depressing the General Reset Key Insert Side B of Program Card				
12	(Note: If it is desired to add the new data to a previous fit then simply add the previous n, $\Sigma \text{Log} X$ , $\Sigma (\text{Log} X)^2$ , etc. to the corresponding register in the current print-out and store in the indicated registers. Then Depress RS, Insert Side B and continue with Step 13, depressing RS again)				

Least Square's Fit to a  
Parabolic Function  
 $y = ax^b$

DATE	CODE	NO. OF SIDES	NO. OF INSTRUCTIONS
5/67	4 5 1 5 2 0	3	1 8 2

OPERATING PROCEDURE

	OPERATIONS	DIGIT CAPACITY		EXAMPLE AND/OR REMARKS
	DECIMAL WHEEL SETTING 7 - 10	WHOLE NOS.	DECIMALS	
13	Depress RS			Z
14	Computer prints: Log <sub>a</sub> d◊ b                    E◊ r                    A◊ s                    A◊			$n = 14 \text{ R} \circ$ $\sum \text{Log} X \quad 9.51141431 \text{ b} \circ$ $\sum (\text{Log} X)^2 \quad 7.25107858 \text{ c} \circ$ $\sum \text{Log} Y \quad 0.96701158 \text{ B} \circ$ $\sum \text{Log} X \text{Log} Y \quad -0.05161417 \text{ C} \circ$ $\sum (\text{Log} Y)^2 \quad 0.76280178 \text{ D} \circ$ <p style="text-align: center;">- INSERT SIDE B -</p> $\text{Log} a \quad 0.67910338 \text{ d} \circ$ $b \quad -0.89791439 \text{ E} \circ$ $t_{\text{Log} X \cdot \text{Log} Y} \quad -0.95610925 \text{ A} \circ$ $s_{\text{Log} X \cdot \text{Log} Y} \quad 0.06533199 \text{ A} \circ$ <p style="text-align: center;">- DEPRESS RESET AND INSERT SIDE C -</p> $0.67910338 \text{ S}$ $-0.89791439 \text{ S}$ $a = 4.77642946 \text{ A} \circ$ $a^{-1/b} = 5.70573930 \text{ b} \circ$
15	Return to Step 1 for a new set of points. If it is desired to plot the fitted curve on Log-Log paper go to Step 16			
16	Depress General Reset Key			
17	Insert Side C of Program Card			
18	Depress V			
19	Enter Log <sub>k</sub> a and Depress Start			
20	Enter b and Depress Start			
21	(Note: these parameters may be from any curve desired. Side C is independent of Sides A and B)			
22	Computer prints: a                            A◊  a <sup>-1/b</sup> b◊			
23	Return to Step 16 for plotting a new curve with Log a and b known.			
24	Return to Step 1 for fitting a new curve.			

- A Register, 7, 18, 20
- Absolute Value, 29
- Accumulator, 7
- Addition, 24
- Addresses, Register, 13
- Arithmetic Keys, 14
- Arithmetic Operations, 23-29
- Arithmetic Unit, 6
- Automatic Internal Checks, 16, 38
- B Register, 7, 9
- b Register, 7, 9
- Branching, 30
- C Register, 7, 9
- c Register, 7, 9
- Capacity
  - memory, 7
  - register, 7
  - printing, 7
- Card, Magnetic Program, 9, 11, 36, 38
- Card Reader/Recorder, 6
- Chaining Program Cards, 53
- Clear Entry Key, 13, 36
- Clear Key, 14
- Clear Operation, 17
- Combination Mode, 39
- Conditional Jumps, 32
- Constants
  - entry, 34
  - generation of, 35, 49
  - in a program, 35
  - storage of, in registers, 34
- Control Unit, 6
- Correct Performance Light, 11
- Counters, 50
- D Register, 7, 9, 21, 37
- d Register, 7, 9, 21, 37
- D-R Exchange, 21, 53
- Decimal
  - handling, 15
  - point key, 13
  - wheel, 11, 15
- Decimal Part to M, 22, 47, 51
- Division, 27
- Domino Technique, 52
- E Register, 7, 37
- e Register, 7, 37
- Error
  - detection, 37, 38
  - light, 11
- Exchange, 20
- External Storage, 36, 53
- F Register, 7, 9
- f Register, 7, 9
- From M, 19
- General Reset Key, 11
- Green Light, 11
- Instructions
  - program, 17-29
  - to enter, 36
- Instruction-Data Storage, 47
- Instruction Registers, 8
- Jumps, 30
  - conditional, 32, 33
  - instructions, 31, 32
  - unconditional, 31
- Keyboard
  - diagram, 12
  - function of, 11
  - locked, 11
  - release key, 11
- Loops, 30-33
- M Register
  - capacity of, 7
  - function of, 7, 22, 23
- Magnetic Program Card, 11
- Magnetic Card Reader/Recorder, 6
- Manual Mode, 39
- Median Register, 7
- Memory, 7
- Numeric Entry, 13
- Numeric Keyboard, 13
- On/Off Key, 11
- Operating Registers, 7
- Operations
  - arithmetic, 23-29
  - transfer, 18-22
- Packing a Register, 51
- Paper Roll, 43
- Print Key, 14, 17
- Print Program
  - how to, 37
  - switch, 11
- Printing Unit, 6
- Program
  - creating a, 36, 41
  - operating a, 38
  - recording a, 36
- Program Mode, 38
- R Register, 7, 21, 23, 53
- Read/Record D and E, 47
- Read/Record Magnetic Card, 6
- Read/Write Device, 11
- Record Program
  - how to, 36
  - switch, 11
- Register Address Keys, 13
- Register Format, 8, 9
- Remainder
  - in division, 27
  - in square root, 28
- Ribbon Changing, 42
- Rounding, 45
- Routine Selection Keys, 13
- Split Key, 13
  - function of, 16
- Split Registers, 7, 16
- Square Root, 28
- Start Instruction Key, 13, 17
- Stop Instruction Key, 17
- Storage Registers, 7
- Sub-Routine, 30, 37
- Subtraction, 25
- Tape Advance, 11
- Tape Release Lever, 11
- Test Instructions, 32, 33
- To A, 18
- Transfer Keys, 14
- Transfer Operations, 18
- Unconditional Jumps, 31
- Vertical Space, 17
- Zero
  - division by, 11, 38
  - testing for, 33



**olivetti canada** *Limited*

1390 Don Mills Road, Don Mills, Ontario 447-3351



# olivetti programma 101

Title _____					
_____					
_____					
Date		Code		No. of cards	No. of instructions
m	yr.	class			

PROGRAM INSTRUCTIONS										CARD NO. _____									
REG. 1		REG. 2		REG. F		REG. E		REG. D											
1		25		49		73		97											
2		26		50		74		98											
3		27		51		75		99											
4		28		52		76		100											
5		29		53		77		101											
6		30		54		78		102											
7		31		55		79		103											
8		32		56		80		104											
9		33		57		81		105											
10		34		58		82		106											
11		35		59		83		107											
12		36		60		84		108											
13		37		61		85		109											
14		38		62		86		110											
15		39		63		87		111											
16		40		64		88		112											
17		41		65		89		113											
18		42		66		90		114											
19		43		67		91		115											
20		44		68		92		116											
21		45		69		93		117											
22		46		70		94		118											
23		47		71		95		119											
24		48		72		96		120											
REG. 1		REG. 2		REG. F		REG. E		REG. D											

CONTENTS OF REGISTER	
<b>M</b>	
<b>A</b>	
<b>R</b>	
<b>b/</b>	
<b>B</b>	
<b>c/</b>	
<b>C</b>	
<b>d/</b>	
<b>D</b>	
<b>e/</b>	
<b>E</b>	
<b>f/</b>	
<b>F</b>	

CONSTANTS ON CARD			CONSTANTS ON CARD		
		↑			↑
		↑			↑
		↑			↑

